

ZA5

Hearing Aid Battery

Technical Data Sheet

Specifications

Chemical system	Zinc / Air
Nominal Voltage	1,4 V
Capacity	35 mAh, Discharge over 3,010 k Ω 12 hours per day at 20°C to 0,9 V
Operating Temperature	0°C – 50°C
Self Discharge	Less than 5% per year at 20°C with label applied
Weight	~0,20 g

**These batteries need air when they are used.
Battery compartment must allow free access of air.**

Dimensions

Diameter	5,80 mm (0,228")
Height	2,15 mm (0,085")

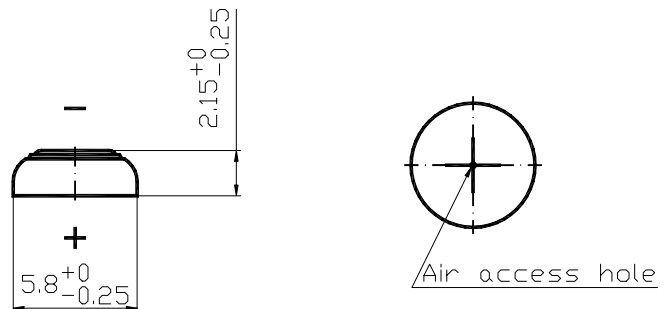

Discharge Curve

12 hours per day at 20°C, 7 days/week, 50% rh

Constant Load	3,010 k Ω
Average current Drain	0,41 mA

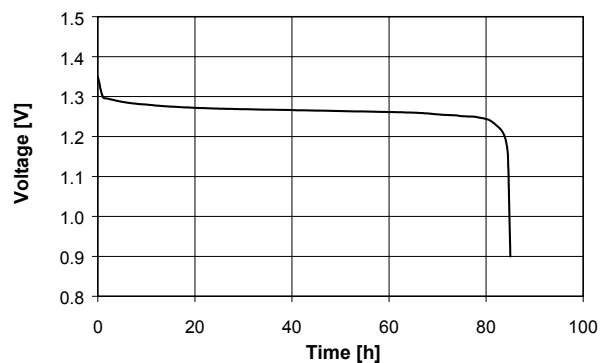

Rev. ZA5.06 06/02